

# Power Characteristics, 20 Hp Diesel and Thoosa 8500

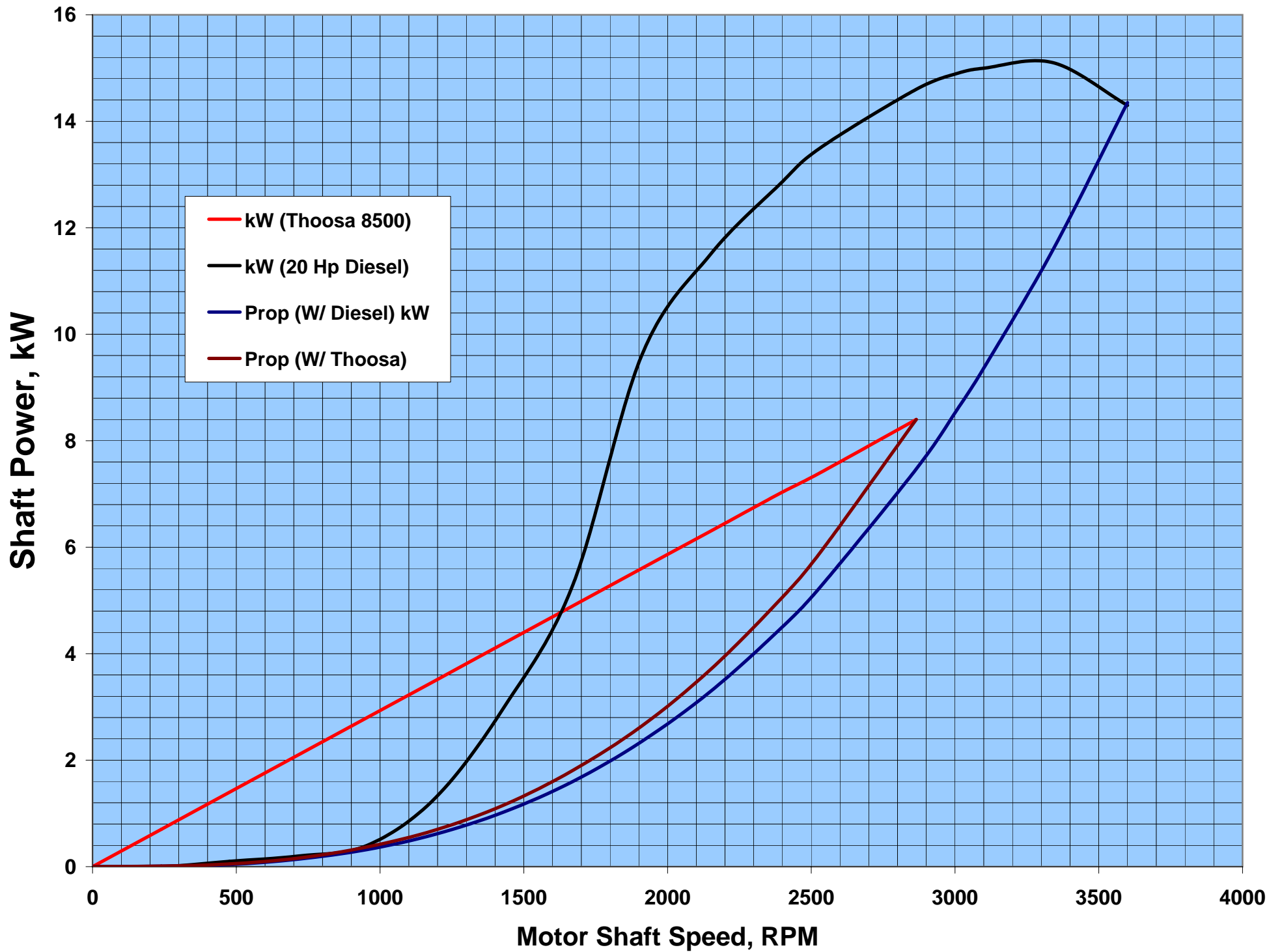

# Torque Characteristics, 20Hp Diesel and Thoosa 8500

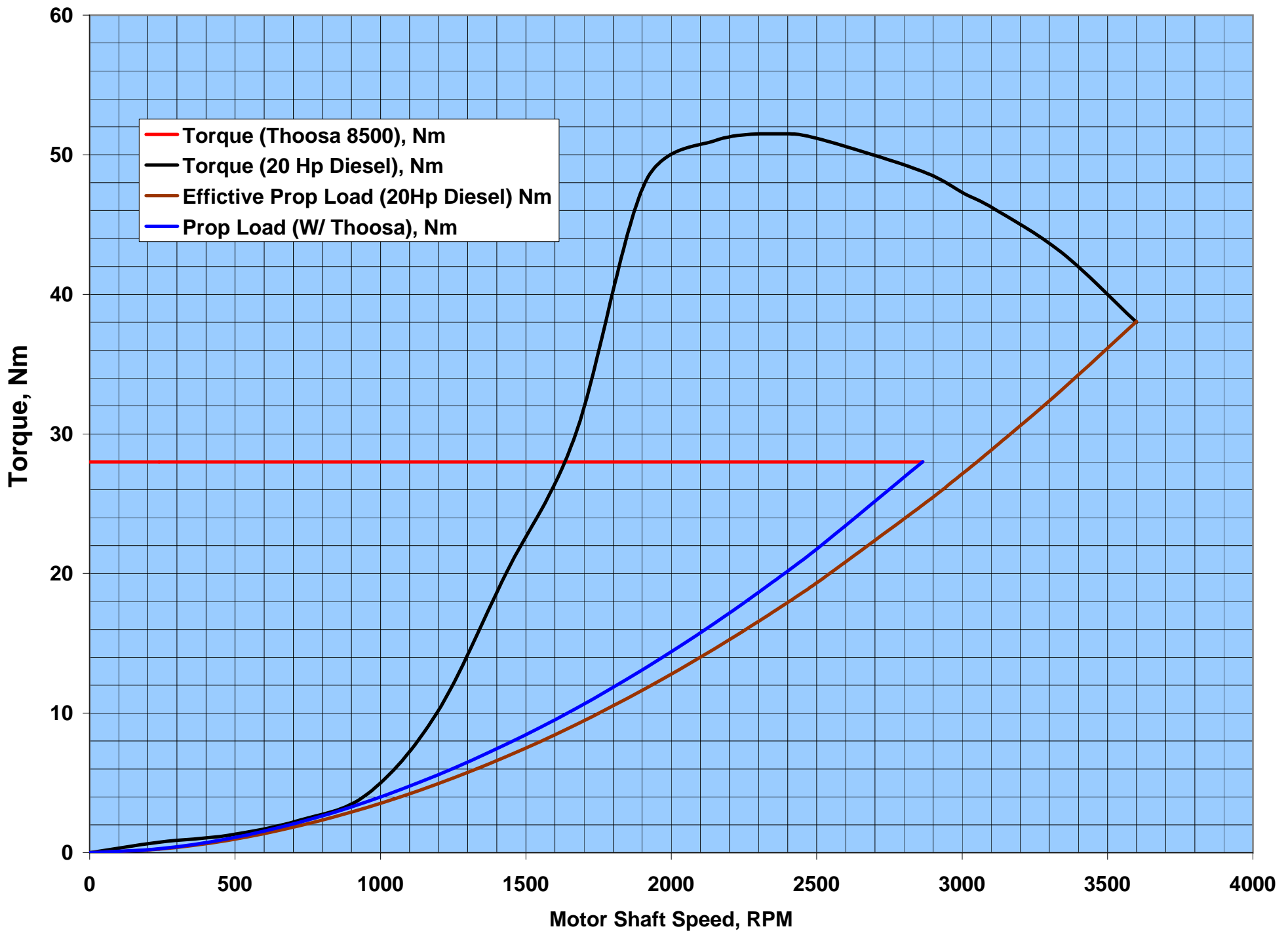

Load Current vs Boat Speed (Bristol 27'). Prop 3 Blade, 12" Dia, 7" Pitch. MK Battery Bank

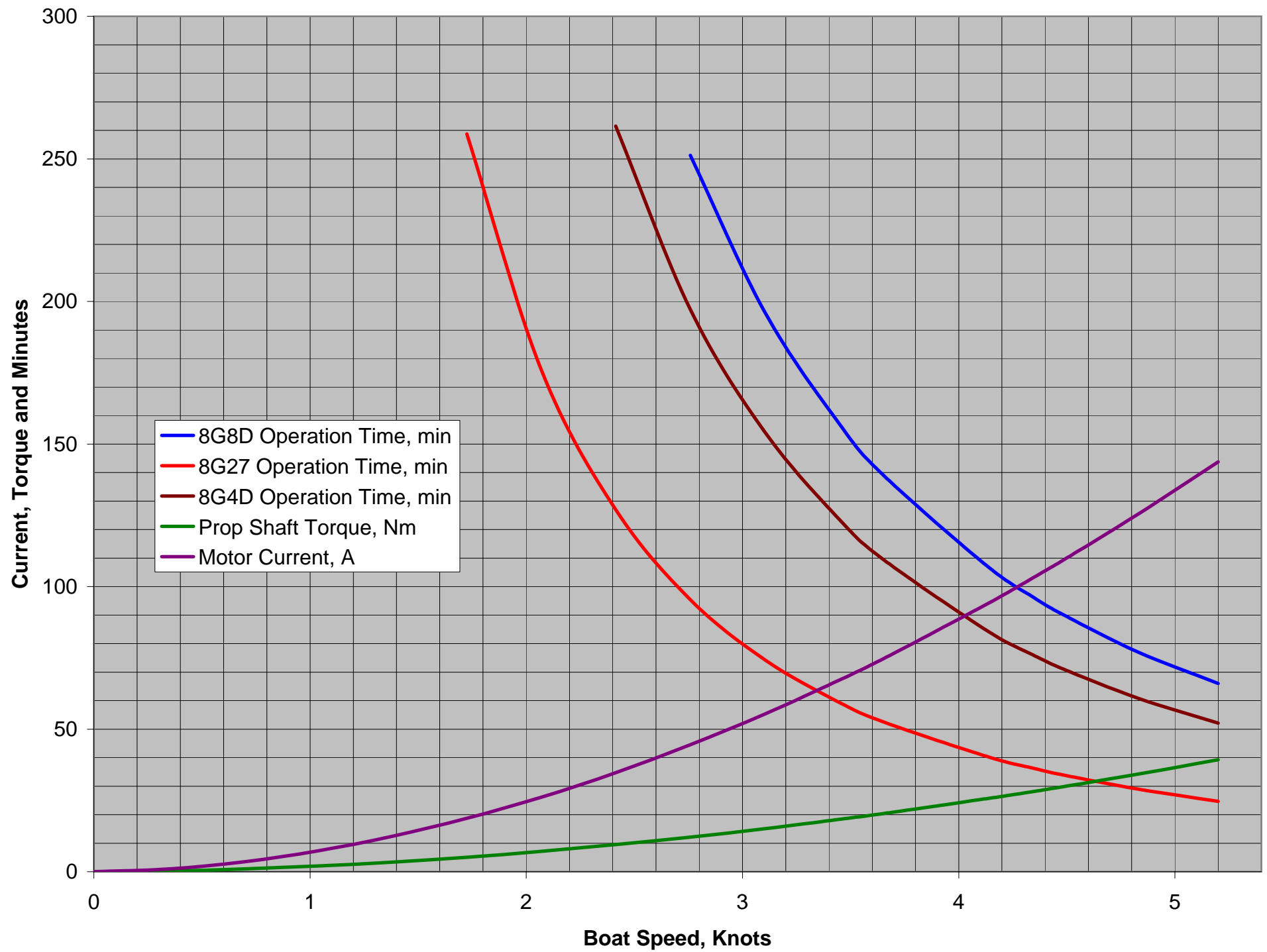

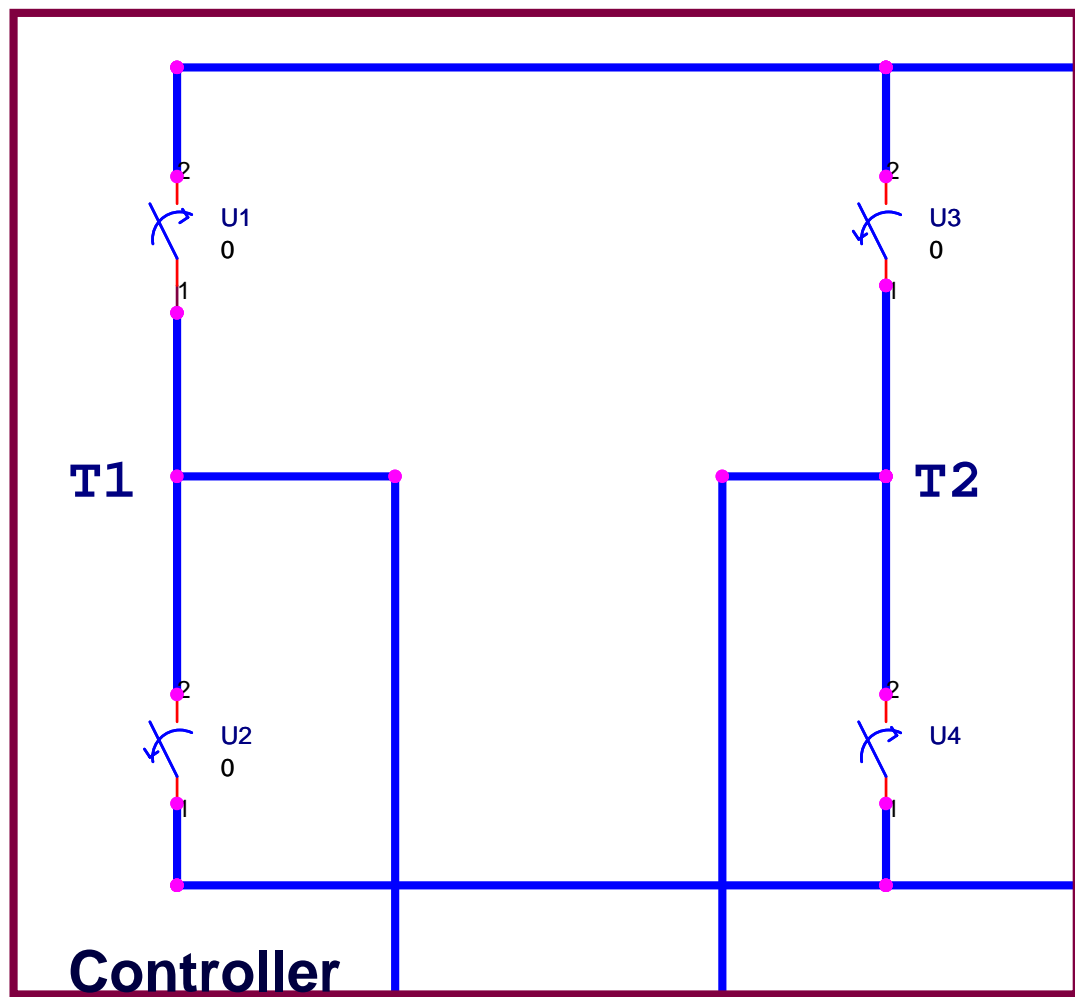

**Battery Bank**

**DC Motor**

# PWM Voltage Generation

